

RD2 FIRST DIVIDER ROUNDER



We provide quality professional equipment and services to artisan bakeries.



MANUAL DIVIDERS ROUNDERS

The use of a divider-rounder machine allows the division of the dough into pieces of equal weight and a rounding for the realization of small round buns.

The equipments of the **RD2 First** range are manual divider-rounders, perfect for dividing and rounding dough of any type and weight, without altering the dough growth process.

They are available in 5 models varying from 14 to 52 divisions.



ERGONOMICS AND HYGIENE

In simple movements, the dough is divided by the oscillating plate which rolls the dough into perfectly rounded and identical pieces. The intensity of the pressing and the duration of the rounding can be adjusted manually according to the type of dough to be worked.

For more mobility, the RD2 First dividers are equipped with wheels that retract when the machine is in use.

The maintenance is simple thanks to an easy access to the different components and the possibility to tilt the cutting disc forward. The Teflon coating on the disc also makes cleaning quick and easy. This machine meets the latest safety and hygiene standards.

CONSTRUCTION

- Epoxy painted steel frame on wheels.
- The putting under pressure and cutting are made by upper lever and the rounding by lateral lever.
- Each machine is delivered with 3 rounding plates whose indentations correspond to the number of divisions chosen.
- Engine protected by a thermal-magnetic circuit breaker.

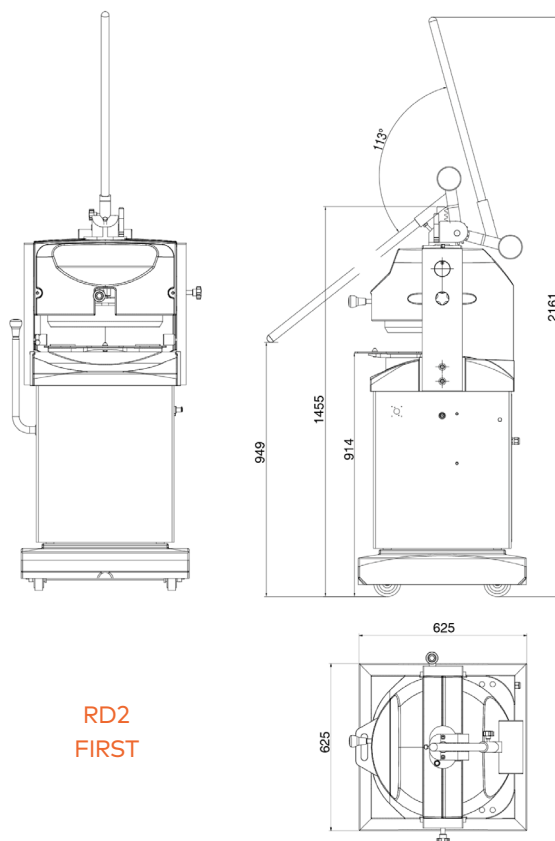

	RD2 14/4	RD2 30/3	RD2 30/4	RD2 36/4	RD2 52/3
Cutting form					
Number of divisions	14	30	30	36	52
Max. capacity of the tank (kg)	4	3	4	4	3
Min. dough pieces weight (g)	85	30	40	30	20
Max. dough pieces weight (g)	260	100	130	110	50
Width (mm)				625	
Depth (mm)				625	
Height with opened cover (mm)				1455	
Working height (mm)				914	
Max. overall width (mm)				625	
Max. overall depth (mm)				625	
Max. overall height (mm)				2161	
Weight (kg)				400	
Electrical supply	400V / TRI+N+T / 50-60 Hz				
Power (kW)	0,55				
Rated current (A)	2				

MANY AND MORE, REAL GOODS



Rue Benoit Frachon, 26800 PORTES-LES-VALENCE (France)
Phone : +33 (0) 475 575 500 - Email : contact@sebp-bertrand.com
www.bertrand-puma.fr - www.pavailler.fr

an Ali Group Company



The Spirit of Excellence