

# OXYGENE

## SPIRAL MIXER

  
MADE IN FRANCE



We provide quality professional equipment and services to artisan bakeries.

  
**BERTRAND  
PUMA**

A close-up photograph of a spiral mixer's mixing blades and dough. The blades are dark and metallic, and the dough is a light, creamy color. The background is a blurred stainless steel surface.

# OXYGENE RANGE

The spiral mixers in the OXYGENE range offer incomparable mixing quality, combining versatility and sturdiness to ensure perfect respect for the dough and your work.

The touch-sensitive interface accompanies the user on a daily basis, enabling easy, personalized management.

The range comprises 5 models, with maximum dough capacities ranging from 45 to 200kg.

KNOW-HOW

## 70 years by your side



With 70 years of experience, Bertrand Puma has reached its high level of expertise thanks to a unique know-how in the conception of equipments for bakeries and pastry shops, and a development of Made in France products, always more reliable and efficient.

VISIT

[WWW.BERTRAND-PUMA.FR](http://WWW.BERTRAND-PUMA.FR)

LAB

## Discover your future equipment



As a demonstration and training center, our LAB' is at your disposal to test our equipment in real-life situations. Our Baker Demonstrator is there to advise and assist you.

MAKE AN APPOINTMENT WITH US  
[+33 \(04\) 75 57 55 00](tel:+330475575500)

ASSISTANCE

## At your service



Benefit from the power of a worldwide network of distributors! We provide local support to bakers all over the world, to help you at every stage of your project.

CALL US  
[+33 \(04\) 75 57 55 00](tel:+330475575500)

# GIVE PRIORITY TO THE QUALITY OF KNEADING

The regular movement of the spiral allows the realization of a structured, smooth, coherent and homogeneous dough, thanks to a succession of pressures, stretches and shears.

These results are obtained thanks to the spiral, whose shape, combined with the geometry of the bowl, prevents the dough from rising up along the tool, even for small quantities of dough.

OXYGENE spiral mixers are particularly robust and ensure gentle kneading, without overheating, while respecting the steps necessary for perfect oxygenation.



## A BOWL DESIGNED TO INCREASE EFFICIENCY

The **stainless steel bowl** of the OXYGENE spiral mixers has been specially designed to ensure **efficient and fast frasing** as well as **optimal oxygenation of the dough** by stretching, cutting and blowing it in turn.

Its flat bottom allows a better recovery of the flour on the periphery and a gentle kneading, in order to obtain a **perfect dough consistency**.

An **infrared temperature probe** (optional) detects the surface temperature and displays it on the control panel. A threshold can be set to alert the operator if the set point is exceeded.

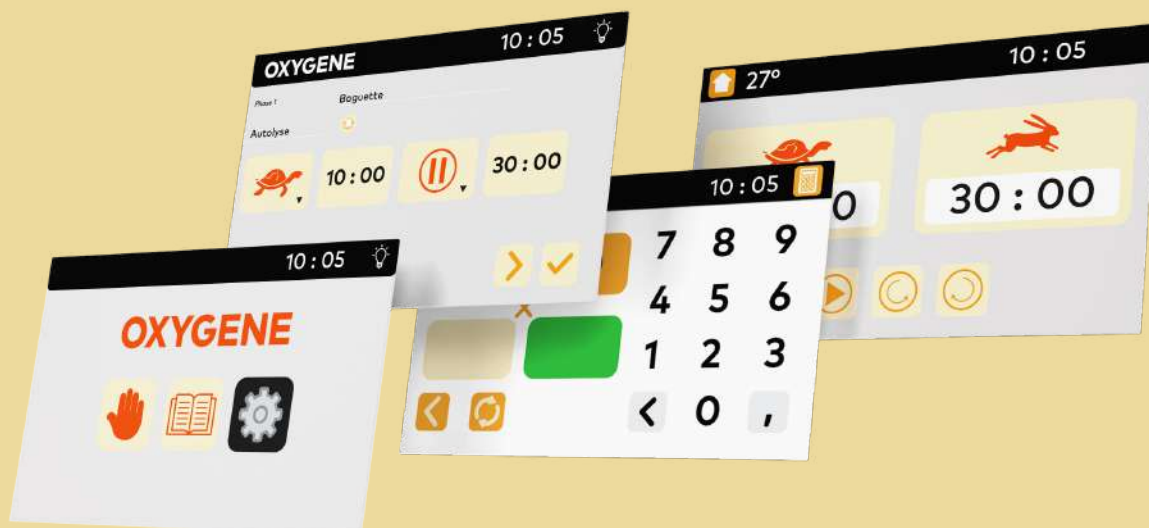

OXYGENE spiral mixers' touch-sensitive controls are easy to use and personalized, allowing you to manage your daily production with peace of mind.

### MANUAL MODE

Set the kneading time in **1st and 2nd speed** via two separate timers.

The **direction of rotation of the bowl can be reversed on demand** for better integration of water into the flour.

### EXPERT MODE

For easy, controlled day-to-day management, Expert mode gives you access to the **parameters** and **production statistics**, as well as the ability to **modify recipes**.

### CALCULATOR

Quickly calculate the proportions of **water, salt and yeast** required for the quantity of flour you need.

### CUSTOMIZABLE RECIPE MODE

Easily define, name, visualize and duplicate your recipes!

Each recipe includes up to **8 programmable phases**, allowing you to define **mixing speeds** (1st and 2nd), **bowl rotation direction, alarms** and even **autolysis** phases and **automatic foldings** phases to facilitate the baker's work and reduce repetitive, tiring tasks.

**A temperature threshold can be set:** beyond this threshold, mixing stops and a message appears. The baker then has the choice of emptying the bowl or continuing to the end of the cycle.



### V-BELT DRIVE

The trapezoidal shape of the V-belts ensures excellent contact with the pulleys.

This **silent** drive solution offers great comfort of use and guarantees an **excellent service life** of the mechanism.



### PERFECT HYGIENE

The **metal frame**, the **anti-floor spillage cover** and the **stainless steel bowl** are very easy to clean.

The **height-adjustable feet ensure excellent stability** during work. The frame, mounted on wheels, allows an easy displacement to facilitate the washing of the floor.



### SAFETY FIRST

The OXYGENE range is equipped with a **safety device allowing the immediate stop of the bowl when the lid is opened**. The spiral mixer is then completely immobilized.

An action of the user is necessary to start again the cycle in full safety.



### ERGONOMICS

The **transparent anti-projection cover reduces the risk of inhaling flour dust**. A trap door allows ingredients to be inserted during mixing.

**Bowl heights comply with ergonomic recommendations** to limit the occurrence of musculoskeletal disorders (ex: 960 mm at bowl edge for model 130).

# DATA AND DIMENSIONS

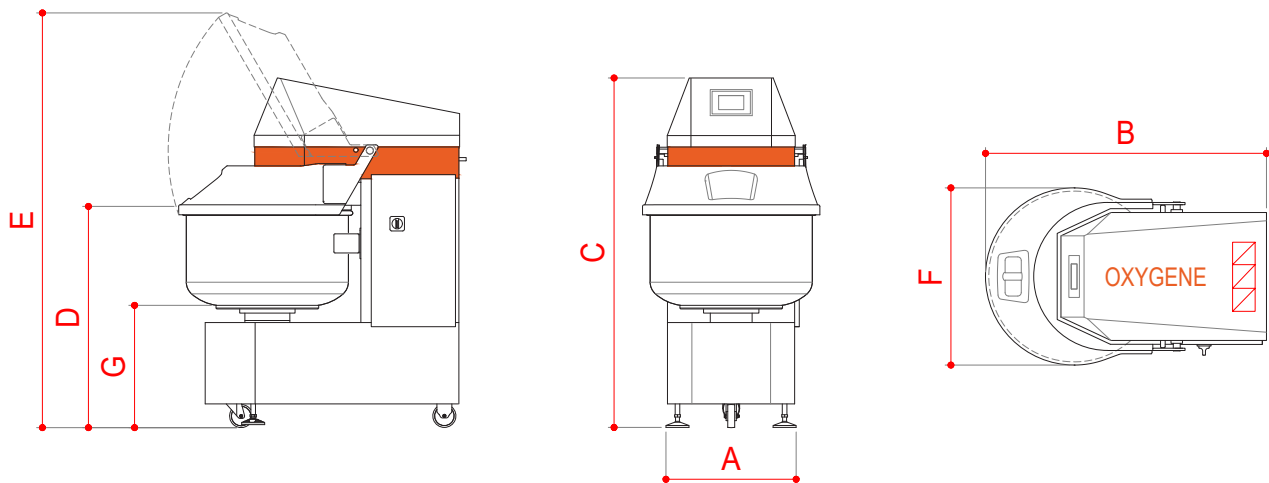

## OXYGENE

● standard – not available

	OXYGENE 45	OXYGENE 60	OXYGENE 100	OXYGENE 130	OXYGENE 200
Maximum bowl capacity (L)	60	95	145	200	290
Min./max. water pouring capacity (L)	1 - 15	1,2 - 20	1,5 - 30	1,5 - 50	1,7 - 60
Min./max. flour capacity (kg)	1,5 - 30	1,8 - 40	2,2 - 62,5	2,5 - 80	2,8 - 125
Min./max. dough capacity (kg)	2,5 - 45	3 - 60	4 - 100	4 - 130	4,5 - 200
Bowl speed (r/min)	10 - 20	7 - 14	7,5 - 15	10 - 20	10 - 20
Tool speed (r/min)	100 - 200	100 - 200	103 - 207	103 - 207	103 - 207
Net weight (kg)	225	360	417	630	705
A - Width (mm)	477	565	588	735	709
B - Depth (mm)	1000	1150	1250	1450	1491
C - Height, closed cover (mm)	1370	1630	1540	1625	1567
D - Working height (mm)	791	911	936	960	940
E - Height, opened cover (mm)	1892	1705	1795	1945	2126
F - Max. overall width (mm)	590	675	771	875	948
G - Bowl bottom height	490	565	535	572	459
Electronic control	●	●	●	●	●
Anti-flour spillage cover	●	●	●	●	●
Bowl inversion	-	●	●	●	●
Electrical supply	400V~TRI+N+T/ 50-60Hz				
Electrical power (kW)	1,50	2,57	4,55	6,80	8,40
Rated current (A)	7,2	7,5	11	14	20

## OPTIONS

€ paying option

OPTIONS	
Infrared temperature probe	€

NON CONTRACTUAL DATA

# MANY AND MORE, REAL GOODS



555 Rue Benoit Frachon, 26800 PORTES-LES-VALENCE (France)  
Phone : +33 (0)4 75 57 55 00 - Email : [contact@sebp-bertrand.com](mailto:contact@sebp-bertrand.com)  
[www.bertrand-puma.fr](http://www.bertrand-puma.fr)

---

an Ali Group Company



The Spirit of Excellence